



**The Federation of Motor Sports Clubs of India**

**2022**  
**Four-Wheeler Technical Regulations**  
**HILL CLIMB RACING**

---

The Federation of Motor Sports Clubs of India  
A-25, Krishna Towers, 50 Sardar Patel Road, Chennai 600113  
Ph: +91 44 22352673, 22355304 Fax: 22351684 email: [info@fmsci.in](mailto:info@fmsci.in) web: [www.fmsci.co.in](http://www.fmsci.co.in)

## **INTRODUCTION**

These rules including the technical regulations, schedules and appendices contained herein, shall govern all competitions in which a 4-wheeler may take part, organized in the territory of the FMSCI under an organizing permit issued by it. These rules shall be valid from **31<sup>st</sup> March 2022**

1. These rules have been drawn up for the proper and equitable conduct of motor sports and are based on the International Sporting Code and the Sporting Code of the FMSCI. The text comprises additions and adoptions drawn up in India to suit local conditions local competitions and local four-wheelers.
2. In so far as they do not conflict with these rules, the supplementary regulations and official instructions applicable to a competition shall be deemed to form part of these rules.
3. The FMSCI has the right to grant an exemption from these rules to suit special conditions or to enable unusual features to be included in the competition and must be specified in the supplementary regulations.
4. International events run under an International Permit issued by the FMSCI must comply with the International Sporting Code as usual. Only refer to these rules in respect of any matter not covered by the Code.
5. Unless otherwise stated, compliance with all regulations in this publication governing groups and classes, safety requirements, lists, technical specifications and definitions is **MANDATORY**.
6. Changes on consideration of **SAFETY MAY BE IMPLEMENTED IMMEDIATELY**. All other changes will be implemented after a notice period, which will be decided by the FMSCI council on a case-to-case basis. The council of the FMSCI, may in its own discretion, authorize immediate implementation if deemed necessary or advisable.
7. Approval of a four-wheeler or a component or its homologation is an indication of its acceptance solely for the purpose of these regulations and is not to be taken as a guarantee or warranty as to the standard of its design or manufacture or its fitness or suitability for any use to which it may be put.
8. Questions or requests for clarification or advice on these technical regulations should be made in writing to the Chairman, Hill climb Racing commission and forwarded to him through the Secretariat. Only those replies / interpretations signed by him will be valid.
9. These technical regulations have been compiled for both safety and eligibility and form the basis of all motor sports in the territory of the FMSCI. They must be studied by Constructors, Tuners, Competitors, Organizers, Scrutineers, Stewards and all others involved with the administration and conduct of motor sports in the territory of the FMSCI in order to ensure total compliance.
10. Definition of free: Wherever the word "FREE" is used in these regulations, without any attached conditions, it is permitted to use any Indian or imported component which may be specially made, the specifications of which are unrestricted in any manner, subject only to conditions of general prescriptions.
11. Read these regulations carefully. Unless these regulations specifically permit variations and/or modifications and/or additional work of any type to be carried out, the same is expressly forbidden. In other words, unless these regulations state that you can do it... **YOU CANNOT**.

## CHAPTER 1: CLASSIFICATION

The following groups and classes are approved by the FMSCland can be technically scrutineered by the FMSCI and protests on technical grounds can be investigated. Organizers are free to run any other classes on closed basis only called as **Promoter classes (a Maximum of 4 classes)**. These promoter classes will not be technically scrutineered and protests will not be entertained.

Cars prepared to circuit racing categories (TC1, TC2, TC3, TC4 & TC5) can participate in any of the Drag Racing categories PROVIDED they meet the requirements of that particular category. In addition, organizers are permitted to run one or more of these categories (TC1-TC5) as a separate Drag Racing category.

Open wheeled Indian Formula cars built for circuit racing are permitted to run WITHOUT any modifications (i.e., In identical homologated form).

No merging of classes even if there are less entries in the case of a Championship.

In the case of a Championship where points are awarded for each round, then full points will be given if there are 6 or more entries in each class and half points will be given if there are less than 6 entries in any class.

### **A) Street Stock Petrol**

- Up to 1150 cc
- 1151 – 1450 cc
- 1451 – 1650 cc
- 1651 – 2050 cc
- 2051 – 2550 cc
- 2551 – 3060 cc
- 3061 cc - 4000cc
- 4001 cc -5100cc
- 5101 cc and above

### **B) Street Stock Diesel**

- Up to 1150 cc
- 1151 – 1450 cc
- 1451 – 1650 cc
- 1651 – 2050 cc
- 2051 – 2550 cc
- 2551 – 3060 cc
- 3061 cc - 4000cc
- 4001 cc - 5100cc
- 5101cc and above

### **C) Pro Stock Petrol**

- Up to 1150 cc
- 1151 – 1450 cc
- 1451 – 1650 cc
- 1651 – 2050 cc
- 2051 – 2550 cc
- 2551 – 3060 cc
- 3061 cc - 4000cc
- 4001 cc -5100cc
- 5101cc and above

### **D) Pro Stock Diesel**

- Up to 1150 cc
- 1151 – 1450 cc
- 1451 – 1650 cc
- 1651 – 2050 cc
- 2051 – 2550 cc
- 2551 – 3060 cc
- 3061 cc - 4000cc
- 4001 cc -5100cc
- 5101 cc and above

### **E) Indian Open**

### **F) Unrestricted**

### **G) 4-wheel drive SUV/MUV (sub 4m)**

### **H) SUV/MUV (over 4m)**

### **I) INRC Cars**

### **J) INAC cars**

### **K) EV OPEN**

## Chapter 2

### 2.1 Specific Regulations

#### **For groups (A&B)**

**Street Stock Diesel and Petrol, the car must be as supplied by the manufacturer and sold commercially in India, CBU /CKD cars permitted.**

**Roll cage is as defined under the heading roll cages in the General Safety Regulations**

**Only the following modifications are permitted**

1. The Engine block, cylinder head and gearbox casing should be as supplied by the manufacturer. Internals are free  
Cylinder head machining free. ECU and necessary wiring is Free.
2. Clutch and flywheel: Free
3. Only seats, floor mats, spare wheel and tool kit /jack may be removed.
4. Body kits like lip spoiler, side skirts, rear spoiler are permitted, provided they are fitted on the OE part without the OE part being cut/altered.
5. Alloy wheels and wider tyres permitted provided they are within the framework of the OE body when viewed from the top.
6. **All DOT/ARAI approved street legal tyres permitted. Drag racing slicks/slick tyres/cut/grooved slicks are NOT permitted.**
7. Exhaust System FREE.
8. Intake system should be as supplied by the manufacturer. OE replacement filter element only is permitted.
9. Only Two wheel drive cars are permitted
10. OE Turbocharged/Supercharged Petrol cars will have a multiplication factor of 1.7. No multiplication factor for Diesel cars.

### 2.2 Specific Regulations

#### **For groups (C &D)**

**Pro-stock Diesel and Petrol, the shell should be a production shell from a car sold commercially in India. The chassis or unitary construction must remain as supplied by the manufacturer.** CBU /CKD cars permitted.

**Roll cage is as defined under the heading roll cages in the General Safety Regulations**

**Only the following modifications are permitted.**

1. The engine block, head and gearbox casing should be of production type. All internals are free. ECU is Free.
2. Turbo charging / Super charging / Nitrous oxide or a combination of any are allowed, with a multiplication factor of 1.5 on the cubic capacity for Diesel and 1.7 for Petrol. The same multiplication factor applies to OEM forced induction cars.
3. The front bonnet, bumpers front and rear and front fenders may be replaced with fiberglass, steel, aluminum or carbon fiber with modifications like wheel flares, ducts or vents for intake or exhaust.
4. The rear doors, front passenger door, and the rear boot lid/hatch may be replaced with a copy of the OE part made of fiberglass/composite/steel/ aluminum, or a combination and may be securely fastened and/or bonded to the body, however the front passenger door should be open-able from inside and outside. Ducts are permitted on the rear door for entry/exit of air so long as the identity of the original shape is not compromised. **Driver door should remain as original.** Rear windscreen and door glasses may be replaced with clear Perspex/Lexan.
5. Headlights may be removed. However, the opening must be covered with fiberglass/metal unless the opening is used as an air intake duct.
6. Clutch and Flywheel: Free
7. Wheels and tyres Free
8. Exhaust System Free
9. Intake system Free
10. All other main systems like brakes, driveshafts, cooling, wiring and electronics, shock absorbers/dampers/struts and

instrumentation are Free

11. All fiberglass should be a minimum thickness of 2 mm.

### **2.3 Specific Regulations**

**For group(E)**

**Indian Open**

**Roll cage is as defined under the heading roll cages in the General Safety Regulations**

This class is open to all cars sold commercially in India / Custom cars built in India. **INTERNAL COMBUSTION ONLY**  
Engine must be from any vehicle commercially sold in India (e.g. Car, Bus, Truck, Motorcycle, etc.), internals are free.

Number of engines: One. Location: Free

Gearbox: Free.

Number of gearboxes: One. Location: Free

Where a production body shell is modified for fitment of the engine in the rear, the shell must be integrated with the roll cage and all safety precautions should be taken. In such cases a firewall separating the driver from the engine compartment is mandatory.

Custom built space frame chassis are permitted provided all safety norms are met. Firewall is mandatory, Body work is compulsory, but shape and contours are Free.

Exhaust System: Free Intake system: Free. Clutch and Flywheel: Free

Turbo charging / Super charging / Nitrous oxide or a combination of any is permitted Fuel: Free

Brakes, wheels, tyres, suspension & steering are Free

Fuel tank and fuel lines **not** permitted in the driver compartment. In case of hatch back vehicles if the fuel tank is in the spare tyre wheel well, a firewall separating the driver is mandatory.

**Minimum weight for cars is 600kg with all fluids and fuel.**

The driver's equipment will have to comply with the FMSCI Racing Safety Regulations.

### **2.4 Specific Regulations**

**For Group (F)**

**Unrestricted**

**Roll cage is as defined under the heading roll cages in the General Safety Regulations**

This class is open to all cars with **Indian / Foreign engines, Foreign cars/ Hybrids and Electric** vehicles

Engine: Free; Number of engines: Free; Location: Free.

Gearbox: Free; Number of gearboxes: Free; Location: Free.

Where a production body shell is modified for fitment of the engine in the rear, the shell must be integrated with the roll cage and all safety precautions should be taken. In such cases a firewall separating the driver from the engine compartment is mandatory.

Custom built space frame chassis are permitted provided all safety norms are met.

Firewall is mandatory.

Body work is compulsory, but shape and contours are Free

Fuel: Free; Fuel tank and fuel lines not permitted in the driver compartment.

Brakes, wheels, tyres, suspension, steering are Free.

**Minimum weight for cars is 700kg with all fluids and fuel.**

The driver's equipment will have to comply with the FMSCI Racing Safety Regulations attached separately

## 2.5 Specific regulations for group G &H

This category will be run with the same regulations as given under **article 2.1 above ( Street stock Petrol and Diesel)**,

**EXCEPT that Turbo charging / Super charging / Nitrous oxide or a combination of any are allowed, THERE WILL BE**

### **NO MULTIPLICATION FACTOR**

These groups will be split into two cubic capacity classification

**a) Upto 2500 cc                      b) 2501 and above**

## 2.6 Specific regulations for group I ( INRC cars)

The cars entered in this class will follow the regulations of the INRC and grouped accordingly as defined therein.

Please refer the FMSCI regulations @ <http://www.fmsci.co.in/4w-rally-technical-regulations-2021/>

## 2.7 Specific regulations for group J ( INAC cars)

The cars entered in this class will follow the regulations of the INAC and grouped accordingly as defined therein.

Please refer the FMSCI regulations @ <http://www.fmsci.co.in/4w-auto-cross-technical-regulations-2020/>

## 2.8 Specific Regulations for group K ( EV OPEN)

**Roll cage is as defined under the heading roll cages in the General Safety Regulations**

This is a category open to **only electric vehicles( ICE vehicles and hybrids are NOT permitted )**

## **GENERAL SAFETY REGULATIONS**

Please note that **these are minimum safety regulations for ALL 4-wheel vehicles**. Specific requirements for classes will take precedence over these general regulations.

### **DRIVER COMPARTMENT**

Driver compartment must be totally sealed from engine, transmission and fuel tank. All holes in firewall must be sealed with aluminum or steel. Openings around all linkages, lines, wires, hoses, etc. must be minimized. Battery and its cables are not permitted in the driver's compartment.

### **FIREWALLS**

Each car in competition must be equipped with a minimum .032-inch (.8 mm) aluminum or .024-inch (.6 mm) steel firewall, extending from side to side of the body and from the top of the engine compartment's upper seal (hood, cowl, or deck) to the bottom of the floor and/or belly pan. Firewall must provide a bulkhead between the engine and/or fuel tank and driver compartment. All holes in firewall must be sealed with aluminum or steel. Use of magnesium prohibited.

### **SAFETY HARNESS**

Any cars with roll cages - 4-point harness is mandatory. For all other cars, 3-point harness is mandatory, however a 4-point harness is recommended.

**ROLL CAGES:**

Roll cage as per drawing 1 is recommended for all cars,

1. Custom built Cars participating in the Indian Open categories roll cage as per drawing 1 is mandatory.

2. Unrestricted category roll cage as per drawing 1 is mandatory.

**Roll cages exceeding the spec of drawing 1 are permitted** ( eg . Roll cage for ITC cars )

All cars with an OEM frame must have rollbar attached to frame.

Cars without frame use 6" (152mm) square 1/8" (3.2mm) steel plates on top and bottom of floor, securely bolted together with at least four 3/8" (9.53mm) bolts, or top plate welded to rocker sill.

All materials must be 1.75" OD x .118" (44.5 x 3.02mm) mild steel or .083" (2.11mm) 4130 chrome moly tubing, except for **A** which is 1.25" OD x .118" (31.8 x 3.02mm) mild steel or .083" (2.11mm) 4130 chrome moly tubing.

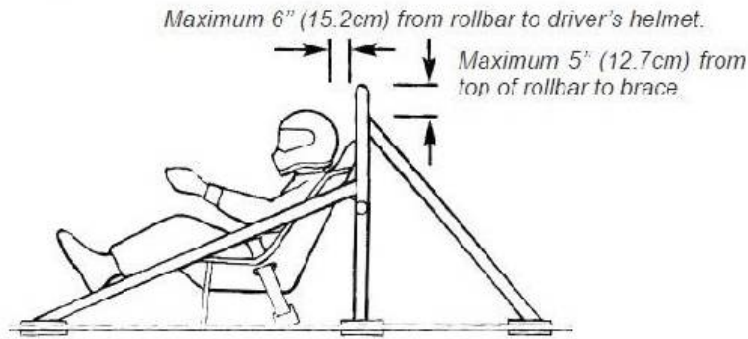
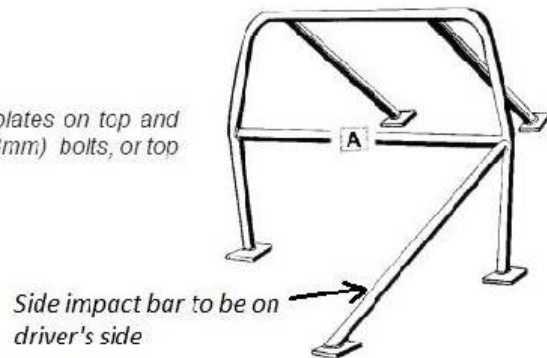

### Drawing No.1

#### HELMETS

- Drivers need to wear Helmets as per specifications defined in the FMSCI Racing Regulations.
- All open wheel cars/custom built cars, drivers need to wear Helmets with either DOT or EC Approvals. Poly Carbonate Helmets are not permitted.
- ISI Helmets are allowed however helmets as defined in the FMSCI safety regulations ( link below) are recommended.

#### OVERALLS, GLOVES, SHOES, ETC.

- All Drivers the following needs to be adhered to: Full-length pants; short or long-sleeved shirt; closed shoes; and socks. No shorts. No tank tops. No open-toe or open heel shoes or sandals. Synthetic clothing not recommended.



- It is strongly recommended to wear overalls and gloves as per the FMSCI Safety regulation. This is compulsory for open wheel cars and custom-built cars

**PLEASE REFER TO THE FMSCI SAFETY REGULATIONS <http://www.fmsci.co.in/safety-requirement-for-4-wheelers/>**

\*\*\*END\*\*\*