



The Federation of Motor Sports Clubs of India

2021

Specific Technical Regulation

for

LGB 1300



Federation Internationale
de l'Automobile



Federation Internationale
de Motocyclisme

Specific Technical Regulations for LGB 1300

1.1 Minimum Weight

The minimum weight of the car with water, oil, fuel and the driver (Wearing Racing gear and Helmet) is 530Kgs.

These minimum weights must be respected at all times during the event.

2.1 Ballast

It is permitted to complete the weight of the vehicle by one or several ballasts, provided that they are safely secured, visible and approved by the scrutineer.

The Ballast must be fixed using two 8mm bolt with self locking nut.

Ballast fixing bolts and nuts must be visible and accessible for the scrutineer for sealing.

3.1 Suspension

3.1.1 Spring

Length and rating FREE

Material must be steel

Coil Spring type only

3.1.2 Shock absorbers

Length FREE

Non adjustable hydraulic/gas telescopic type only

Body can be alloy or steel

3.1.3 Mounting

Suspension mounting points must remain as OE

4.1 Wheels (Art 801)

Diameter respected to Homologation.

Width of the rim free, offset free but the track width must be respected to Homologation.

5.1 Filter

Fitted or Removed

6.1 Engine

6.1.1 Cylinder Capacity (Art 307)

a) Unitary – 325cc

b) Total Corrected – 1300cc

6.1.2 Total Minimum Volume of a Combustion Chamber (Art 308)

Art 308 Shall not Apply

6.1.3 Maximum Bore Allowed (Art 315)

Maximum bore allowed is 74.18mm

6.1.4 Piston (Art 317)

b) Thickness of Rings

i) 1st Ring – 1.2mm ± 0.1 mm

ii) 2nd Ring – 1.2mm ± 0.1 mm

iii) 3rd Ring – 2.4mm ± 0.1 mm

c) Minimum Weight

Minimum weight of the Piston is 292g.

Minimum weight of the Piston measured with Rings, Clips & Piston Pin.

6.1.5) Connecting Rod (Art 318)

e) Minimum Weight

Minimum weight of the Connecting Rod is 382g.

Minimum weight of the Piston measured with Cap, Bolts & Shell Bearing.

6.1.6) Flywheel (Art 320)

b) Minimum weight

Minimum weight of the Flywheel is 4915g.

Minimum weight of the Flywheel measured with Fixing Bolts, Center Bearing & Starter Ring.



6.1.3) Cylinder Head (Art 321)

c) Minimum Height

Minimum height of the Cylinder Head is 119.80mm.

Note:

The above changes are required due to non availability of parts for this engine (since the production of this Vehicle has stopped almost 10 years back).

7.1 Brake Light

Free

Brake light must glow a minimum area of 22 sq cm.

Brake light must glow in red color only.

Final decision will be taken by the scrutineer on the position/fixing and visibility of brake light.

8.1 Fuel Pump (Art 402)

Fuel Pump free.

Number of fuel pump and Location respected to Homologation.

Fuel Pressure Regulator, Fuel Rail, Injector and their mountings must be OE.

9.1 Exhaust Manifold (Art 328)

Exhaust Manifold Dimensions

9.1.1 PRIMARY PIPE

C1 – Length 690mm, Diameter 38mm, Thickness 1.6mm

C2 – Length 615mm, Diameter 38mm, Thickness 1.6mm

C3 – Length 660mm, Diameter 38mm, Thickness 1.6mm

C4 – Length 675mm, Diameter 38mm, Thickness 1.6mm

9.1.2 SECONDARY PIPE

C1 & C4 – Length 95mm, Dia 44.5mm, Thickness 1.6mm

C2 & C3 – Length 95mm, Dia 44.5mm, Thickness 1.6mm

9.1.3 Two into One PIPE 'Y'

2 into 1 'Y' 450mm Length

9.1.4 TAIL PIPE

Length 700mm, Dia44.5mm, Thickness 1.6mm



10.1 ECU

All LGB 1300 Cars competing in any National Championship/Series/Cup/Open/Challenges must only use the ECU shown in below image. ECU and its Wiring Harness must be as supplied by the supplier.



11.1 Safety Requirements

As per FMSCI 4W Safety Requirements

A minimum clearance of 50mm must be there between the Driver helmet and a straight line drawn from the top of the Front roll hoop to top of the Main roll hoop (As per Figure-1). It will be measured when Driver in the racing position with fastening the seat belts and wearing the safety

gears.

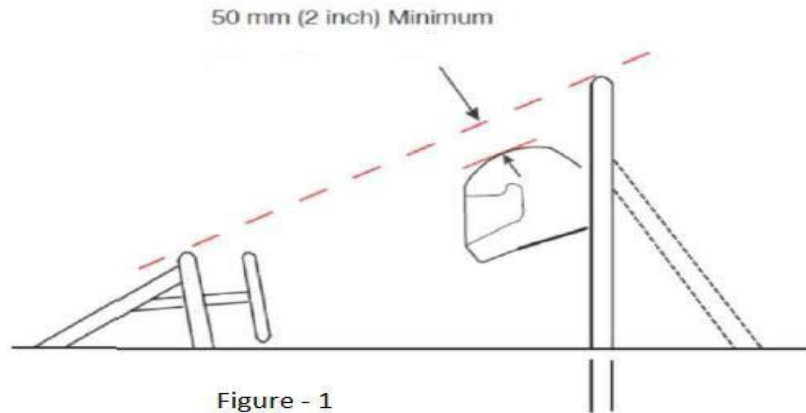

12.1 Rear view Mirror

Rear view mirror Free

Number of rear view mirrors and its Location must be as supplied by manufacturer. Viewing area of the rear view mirror must not be less than that of OE rearview mirror.

13.1 Front Upright center Bolt

Front upright center bolt is "Free"

Any Bolts available in Indian market/modified/Specially made may be used.

Note:

Other than the above said changes rest should follow **LGB 1300 Homologation Form.**

*****All new changes to the regulation are highlighted in Red*****