



The Federation of Motor Sports Clubs of India

National Sports Federation recognized by the Government of India

2019 Technical Regulations for ESTEEM CUP (TC5)

Member of



Federation Internationale de l' Automobile



Federation Internationale de Motocyclisme

Index

1.1 ENGINE	3
2.1 SAFETY	3
3.1 MODIFICATIONS	3
4.1 MINIMUM WEIGHT	3
5.1 ECU	4
6.1 FUEL TANK AND PUMP	4
7.1 ENGINE AND GEAR BOX MOUNT	4
8.1 EXHAUST	4
9.1 FUEL PURGE CANISTER & RESONATOR BOX	5
10.1 CLUTCH	5
11.1 GEAR BOX	5
12.1 DIFFERENTIAL	5
13.1 SUSPENSION	5
14.1 WHEELS	6
15.1 BRAKING SYSTEM	6
16.1 EXTERIOR	6
17.1 INTERIOR	6
18.1 DOORS	7
19.1 FUEL	7
20.1 ROLL CAGES	7
21.1 SEAT BELT	8
22.1 FIRE EXTINGUISHER SYSTEMS MOUNTED	8
23.1 WINDOWS	8
24.1 A/C & HEATING COMPONENTS	8
25.1 REINFORCEMENT OF APRONS (FRONT)	9
26.1 STEERING	9
27.1 RADIATOR	9
28.1 WATER PUMP PULLEY	9
29.1 BALLAST	9

2019 Technical Regulations for Esteem Cup (TC5)

The following Articles of 2019 FMSCI racing regulations is applicable:

Art.251 – Classification and Definitions

Art.252 – General Prescriptions for Production Cars (Group N), Touring Cars (Group A)

Art.253 – Safety Equipment (Groups N, A)

Art.254 – Specific Regulations for Production Cars (Group N)

Changes to the above Articles specific to 2019 Esteem Cup Car are reproduced below:

1.1 Engine

Maruti 1000 and Maruti Esteem cars shell and fitted with Maruti Esteem MPFI engines only.

Maruti Zen, Esteem and Swift Blocks may be used as long as the same dimensions of the homologated Esteem block are maintained.

2.1 SAFETY

All safety equipment that is used - seats, seatbelts, helmet, gloves, balaclava, shoes to be FIA homologated.

2019 FMSCI racing Safety Regulations (Article 253) to be followed.

Protective Padding

Where the occupant's bodies could come into contact with the safety cage, flame retardant padding must be provided for protection.

Rear View

Reward visibility must be ensured by two external rear-view mirrors (one on the right and one on the left).

An inside rear view mirror is optional

3.1 Modifications

Modifications and Adjuncts allowed or obligatory. No Modifications are permitted.

4.1 Minimum Weight

The minimum weight of all Esteem Cup Cars will be cc divided by a constant which is **1.65 WITH DRIVER (i.e. 1298 / 1.65 which is 787kgs rounded down to nearest kg)**. This is the real weight of the car WITH DRIVER (without persons or luggage aboard) without tools, jack. All the liquid tanks (lubrication, cooling, braking, heating where applicable) must be at the normal level foreseen by the manufacturer, with the exception of the windscreen wiper.

5.1 ECU

ENGINE CONTROL UNIT: Free including wiring.

6.1 Fuel Tank and Pump

Only Maruti Esteem MPFI Fuel Tank (see picture below) and MPFI Fuel Pump Assembly is permitted.

Additional fuel pump CANNOT be fitted.



7.1 Engine and Gear Box Mount

The Engine and Gear box mountings are Free provided the number of mounts and location remain as homologated.

8.1 Exhaust

FREE (Exhaust manifold to the exit is free).

However the exhaust ports in the cylinder head should remain as provided by the manufacturer.

The exit of the exhaust may be on the right or left side of the car, behind the mid-point of the wheelbase and below the door sill.

The exhaust system must not be provisional.

Exhaust gases may only exit at the end of the system.

These liberties must not entail any bodywork modifications.

9.1 Fuel Purge Canister & Resonator Box

Fuel Purge Canister and the Resonator Box may be removed.

10.1 Clutch

Only OE Components / aftermarket components permitted so long as homologated data is respected.

11.1 Gear box

Only Maruti Esteem MPFI Gear Ratios are permitted.

12.1 Differential

The use of mechanical type Limited Slip Differential is authorized provided that it can be fitted in the series housing.

13.1 Suspension

Body shell, Shock Absorber and /or Spring Turrets/Perches shall not be modified in any manner (Except addition of a plate for reinforcement of area).

Droop Changes shall be achieved only through Shock absorber length. No special purpose shims and spacers may be used.

Shock absorbers free but only bump and rebound adjustment permitted on shock absorbers (i.e. 2 way adjustable only).

Camber adjustment plates permitted

Cockpit and / or Remote control of shock absorbers is not permitted. Shocks with canisters allowed. Location of Canisters is free.

Springs AND RIDE HEIGHT IS FREE.

Ground clearance must be such that no part of the car touches the ground when two tyres on the same side of the car are deflated, with occupant on board

Spring Rating is FREE.

Shock Absorber Suspension bushes are free.

Reinforcement bars may be fitted on the suspension mounting points (both top and bottom) to the bodyshell or chassis of the same axle, on each side of the car's longitudinal axis, on condition that they are removable and are attached by means of bolts.

14.1 Wheels

The Wheels are free, respecting the homologated maximum diameter. One inch oversize width from the homologated maximum width will be permitted, provided the entire contour of wheels form within the coach work / body work of the car.

Where permitted over size width tyres are used, the Maximum Track Width as per Art.207 of the Homologation Form shall read as

Front – 1395 mm Rear – 1370 mm

Spare wheel must be removed.

No portion of the tyres should be visible when viewed from the top.

15.1 Braking System

No modification is permitted.

Handbrake: Fly off handbrake is permitted.

Brake pads free. As long as the homologated dimensions are respected

16.1 Exterior

A fabricated shield may be incorporated in place of an AC condenser. Hubcaps must be removed.

The bumpers, body skirts, OE spoilers, fog lamps, head lights & front bonnet & fenders and mesh of Maruti Esteem Type 1, Type 2 or Type 3 may be interchanged or used. Front grill mesh may be modified.

The original grill may be replaced with a mesh. Material is free. No other modification to the original opening is allowed.

Headlight maybe removed and the area covered with a plate/panel.

17.1 Interior

Dashboard: The dashboard may be removed Floor: Carpets are free and may thus be removed.

Air conditioning and heater system including all its accessories can be completely removed.

18.1 Doors

Bonnet and boot lid / doors except the driver's side door may be replaced with fiberglass in order to comply with the minimum weights. Door pads and all insulating material may be removed.

Front passenger door must be openable from both inside and outside of the car.

Fiberglass Specification

3mm thickness of Fiberglass is Recommended.

Fire Retardant Resin (FRR) is Recommended in Fiberglass making Ribs in the Fiberglass Bonnet is Recommended.

19.1 Fuel

Only Petrol to be used. No top fuels to be used. No Nitrous oxide or other injectable gasses permitted.

20.1 Roll Cages – AS PER FMSCI RACING REGULATIONS

Basic Structure

The basic structure must be made according to one of the following designs :

1 main rollbar + 1 front rollbar + 2 longitudinal members + 2 backstays + 6 mounting feet (Drawing 253-1)

or

1 lateral rollbars + 2 transverse members + 2 backstays + 6 mounting feet (Drawing 253-2)

or

1 main rollbar + 2 lateral half-rollbars + 1 transverse member + 2 backstays + 6 mounting feet (Drawing 253-3)



253-1



253-2

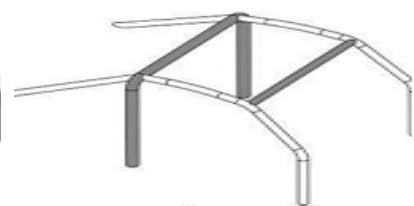

253-3

Compulsory members and reinforcements

Cold drawn seamless unalloyed carbon steel tube (Containing a maximum of 0.3% of carbon) with a minimum tensile strength of 350 N/mm²

The minimum dimensions being 45mm X 2.5mm or 50mm X 2mm.

The basic minimum structural requirement as per Drawing 253-29 with side impact bars as in Drawing 253-11 and roof reinforcement Drawing as in 253-12. (Single Cross member is also allowed in Drawing 253-12).

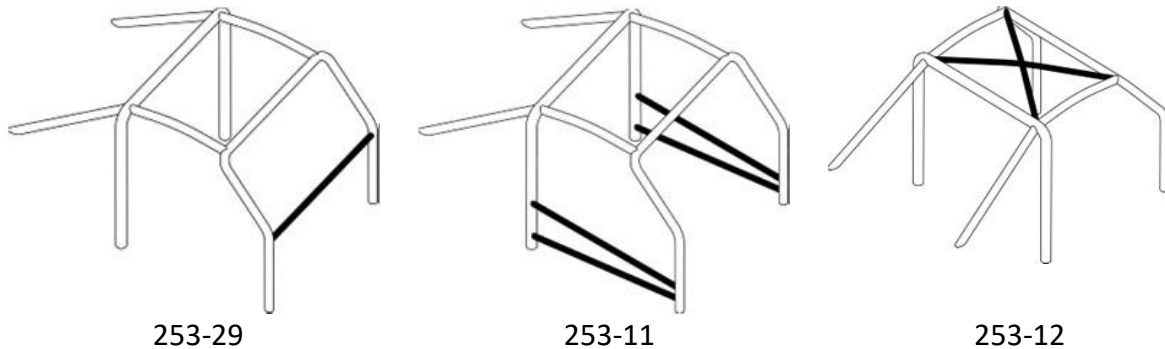

21.1 Seat Belt

Minimum required is a five point harness and following the technical drawings regarding mounting points (Article 253 – 42 to 45, 52 and 53 of Appendix J – FIA Regulations)

22.1 Fire Extinguisher Systems Mounted

The minimum Quantity of Extinguishant for system mounted must be 3kg.

Manual Extinguishers

Minimum Quantity of Extinguishant:

AFFF	2.4 liters
FX G-TEC	2.0 kg
Viro 3	2.0 kg
Zero 360	2.0 kg
Powder	2.0 kg

Fire Extinguishers to be rigidly fastened with a quick release clamps (minimum 2 nos.) fitted in an easily accessible and a visible position. The mounting bracket of the fire extinguisher must be bolted to the floor with a bolt of minimum 10 mm diameter. The bracket thickness – 2mm MS sheet metal

23.1 Windows

Side and Rear Windows : The use of transparent or colourless anti shatter film on the side windows is mandatory.

24.1 A/C & Heating Components

The components relating to the A/C and Heating may be removed so long as the nominated weight of the car is maintained.

25.1 Reinforcement of Aprons (Front)

It is permitted to add a member between the front aprons (Strut Brace), ~~above the front cross member (the front jacking point) provided it is removable and~~ mounted only by means of bolt & nuts.

26.1 Steering

Power assisted Steering Assembly may be removed and replaced with non-power assisted Steering Assembly. All modifications required for fitment of manual steering assembly is permitted.

27.1 Radiator

Radiator, plumbing and its mounting free, provided the radiator subframe is not reinforced. Cooling fan is Free, can be removed.

28.1 Water Pump Pulley

Material and diameter of water pump pulley and Engine Drive pulley are Free.

29.1 Ballast

It is permitted to complete the weight of the car by one several ballast provided that they are strong and unitary blocks, fixed by means of tools with the possibility to fix seals, placed on the floor of the cockpit, visible and sealed by the scrutineers.

**** END ****